

RL-HS Series Heat Sink



Key Features

- ◆ Suitable for a wide range of products
- ◆ With or without fan
- ◆ Power controller can supply the fan with electricity
- ◆ Vibration isolation device between the fan and the heat sink body
- ◆ The fan speed can be automatically adjusted according to the temperature of heat sink

Technical Specifications

Part Number	Parameters	Heat Dissipation
RL-HS-01	Thermal Consumption < 10W @ambient temperature of 25°C	Passively
RL-HS-02	Thermal Consumption < 30W @ambient temperature of 25°C	Actively
RL-HS-03	Thermal Consumption < 5W @ambient temperature of 25°C	Passively

Operation Notes

1. Secure the laser and the heat sink with screws. Fill the gap between the laser and the heat sink with good thermal conductive materials.
2. Adequate air passage is required for the escape of hot air.
3. Beside the power consumption of the laser, its thermal management is also related to the operating method and environment.
4. RealLight is pleased to offer technical support concerning heat dissipation analysis for special applications.

Mounting Examples

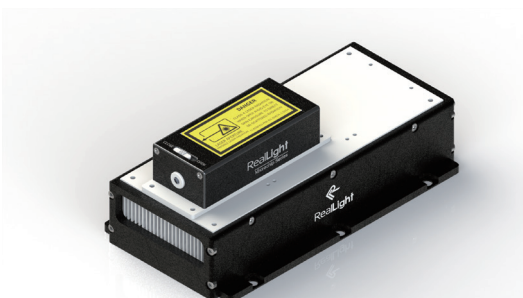



Mechanical Drawings (in mm)

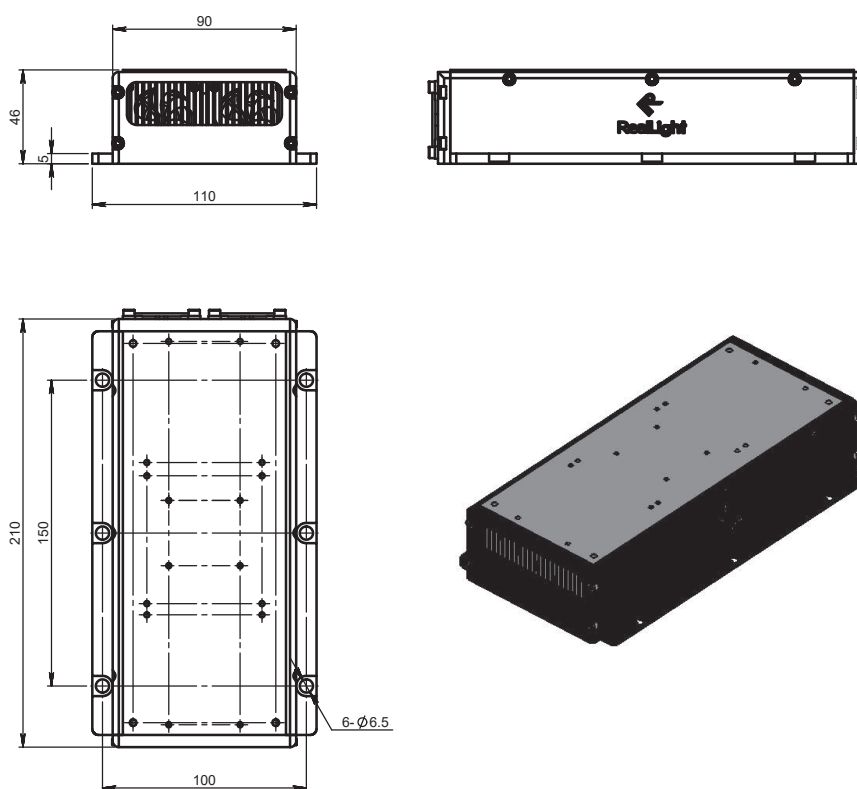

RL-HS-01 & RL-HS-02

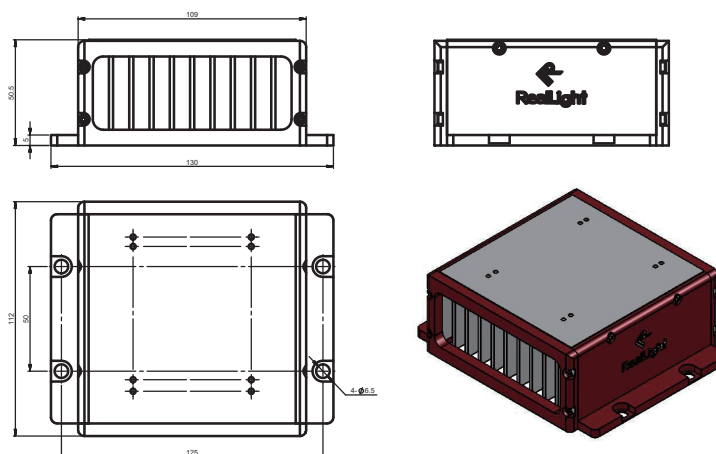

RL-HS-03