

MCH Series 300ps SLM Microchip Laser



Key Features

- ◆ Pulse width down to 300ps
- ◆ High energy stability
- ◆ Repetition rate up to 100kHz
- ◆ Spatial mode TEM₀₀
- ◆ Polarization-stable

Technical Specifications

Optical Parameters							
Wavelength (nm)		1064			532		
Repetition rate (kHz)		20	50	100	20	50	100
Average power (mW)		60	100	100	30	50	50
Pulse energy (μJ)		3	2	1	1.5	1	0.5
Pulse width (ps)		350		500	300		500
Power stability (8h)		±3%					
Beam profile		TEM ₀₀					
Beam full divergence (typ., mrad)	Horizontal @1/e ²	25	30	16	25		
	Vertical @1/e ²	25	30	16	25		
Polarization ratio		>100:1					
System Parameters							
Supply power voltage		100-240 VAC, 50/60 Hz					
Control interface		RS232, USB					
Power consumption (W)		≤35	≤40	≤40	≤35	≤40	≤40
Power dimensions (W×H×L, mm)		168×88×140					
Laser head dimensions (W×H×L, mm)		45×33×120					
Operation temperature (°C)		15~35					
Storage temperature (°C)		0~60					

1. Wavelengths of 355nm and 266nm are available upon request.
2. Other repetition rates can be customized.
3. All the data in the above table are the typical values obtained from the tests at room temperature of 25°C, and the final data is subject to the final test report.

Applications

- Seed laser
- Micromachining
- Raman spectroscopy
- Laser ranging
- Laser-induced fluorescence (LIF)
- Laser ultrasonic imaging
- Bio-photonics
- Photolithography

Order Information

Wavelength (nm)	Part Number	Repetition rate (kHz)	Pulse energy (μJ)
1064	MCH-1064-20-3	20	3
	MCH-1064-50-2	50	2
	MCH-1064-100-1	100	1
532	MCH-532-20-1.5	20	1.5
	MCH-532-50-1	50	1
	MCH-532-100-0.5	100	0.5

Part Numbering Schema

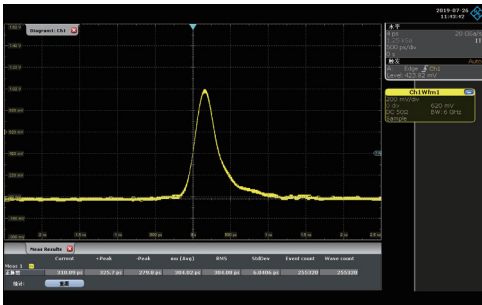
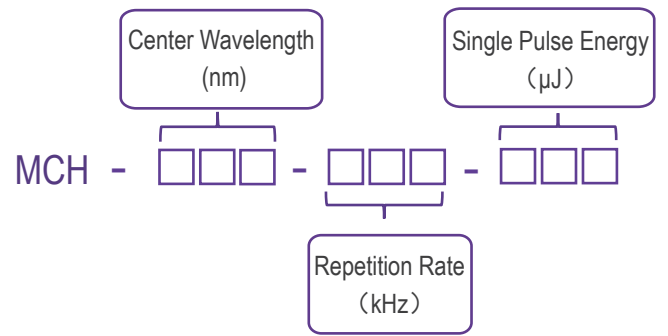

Typical Pulse

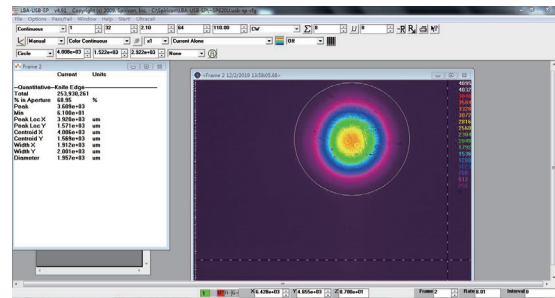

Beam Profile

Mechanical Drawings (in mm)

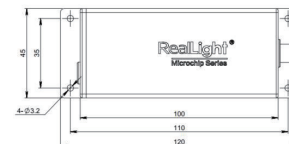
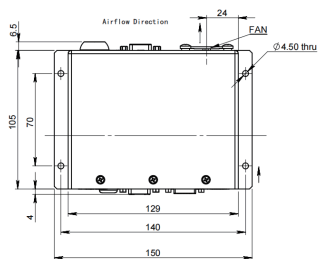
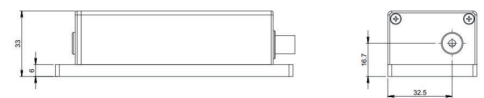
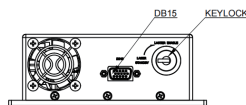
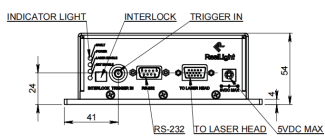

Laser Head

Power Supply

