

2mJ 1535nm Erbium Glass Lasers

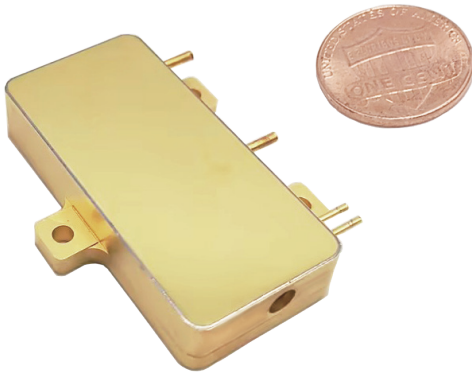

RealLight' s 1535nm Erbium glass lasers operate in the eyesafe wavelength regime, have great advantages in applications including laser ranging and LiDAR. This series of lasers feature no tail pulse, stable pulse energy and excellent beam profile. The integrated design of diode-pumped module and laser crystal brings convenience to installation and integration due to the compact size. The output power of this series is up to 2mJ.

Technical Specifications

Wavelength (nm)	1535
Single pulse energy (mJ)	≥2
Pulse width Typ. (ns)	11
Repetition rate (Hz)	5
Operating current Typ. (A)	70
Voltage (V)	4
Pump pulse width Typ. (ms)	2.5
Beam full divergence (typ., mrad)	4.5
Beam diameter (mm)	0.6
Energy Stability (RMS)	3%
Beam profile	TEM ₀₀
Weight (g)	100
Dimensions (L×W×H,mm)	48x25x12
Operation temperature (°C)	-40~65
Storage temperature (°C)	-55~80
PD output signal	built-in photodiode

Applications

Laser rangefinder
Meteorological radar

Key Features

- ◆ Passively Q-Switched, Er:Glass
- ◆ Eye-safe
- ◆ Extremely light
- ◆ Super compact design
- ◆ Wide operating temperature range

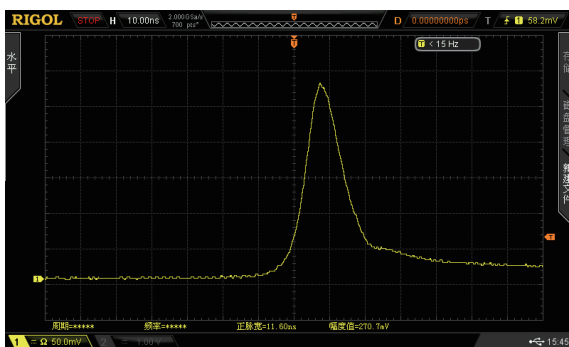

Typical Pluse

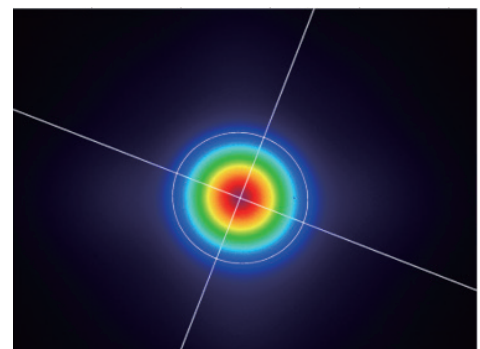

Beam Profile

Order Information

Wavelength (nm)	Part Number	Repetition rate (Hz)	Pulse width (ns)	Single pulse energy (μJ)	Dimensions (mm)
1535	R1535-0.005-11-2000-F11B	5	11	2000	48x25x12

Part Numbering Schema

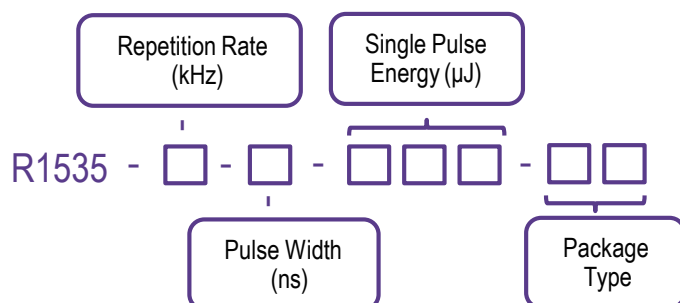

Mechanical Drawings (in mm)

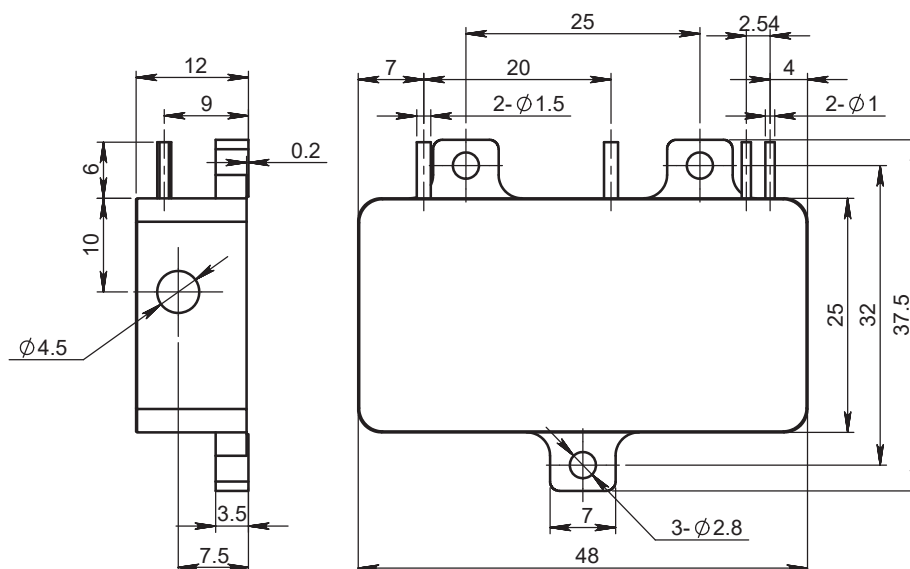

F11B Drawing

