

MCD Series

350ps Microchip Laser



MCD series microchip lasers are RealLight's self-developed, passively Q-switched diode-pumped solid-state lasers, featuring stable single pulse energy, excellent beam quality and no tail pulse. The integrated design of diode-pumped module and laser crystal brings convenience to installation and integration due to the compact size. This series provides various wavelengths include 1064nm, 532nm, 355nm and 266nm, and supports internal and external triggering. The internal hermetic module of the laser head is available to customers for tailor-made development. The MCD series is also available with OEM seed laser drivers.

Key Features

- ◆ Pulse width down to 300ps
- ◆ Single pulse energy up to 100μJ
- ◆ Repetition rate up to 0.1kHz
- ◆ Spatial mode TEM₀₀
- ◆ Polarization-stable

Applications

- Seed laser
- Micromachining
- Laser-induced breakdown spectroscopy (LIBS)
- Laser ionization mass spectroscopy (LIMS)
- Laser-induced fluorescence (LIF)
- Nonlinear optics

Technical Specifications

Optical Parameters					
Wavelength (nm)		1064	532	355	266
Repetition rate (kHz)		0.1	0.1	0.1	0.1
Average power (mW)		10	3	1.5	0.5
Pulse energy (μJ)		100	30	15	5
Pulse width (ps)		350	300	300	300
Power stability (8h)		±3%			
Beam profile		TEM ₀₀			
Beam full divergence (typ., mrad)	Horizontal @1/e ²	12	10	8	8
	Vertical @1/e ²	12	10	8	8
Polarization ratio		>100:1			
System Parameters					
Supply power voltage		100-240 VAC, 50/60 Hz			
Control interface		RS232, USB			
Power consumption (W)		≤25			
Power dimensions (W×H×L,mm)		168×88×140			
Laser dimensions (W×H×L,mm)		45×33×120			
Operation temperature (°C)		15~35			
Storage temperature (°C)		0~60			

1. Please see mechanical drawings for more details.
2. Built-in beam expander and collimator are available upon request, and divergence can be less than 2mrad.
3. OEM seed laser drivers are available.
4. As products are constantly being updated, the right of final interpretation of technical specifications or illustrations in datasheet belongs to RealLight.

Order Information

Wavelength (nm)	Part Number	Repetition rate (kHz)	Pulse energy (μJ)
1064	MCD-1064-0.1-100	0.1	100
532	MCD-532-0.1-030	0.1	30
355	MCD-355-0.1-015	0.1	15
266	MCD-266-0.1-005	0.1	5

Part Numbering Schema

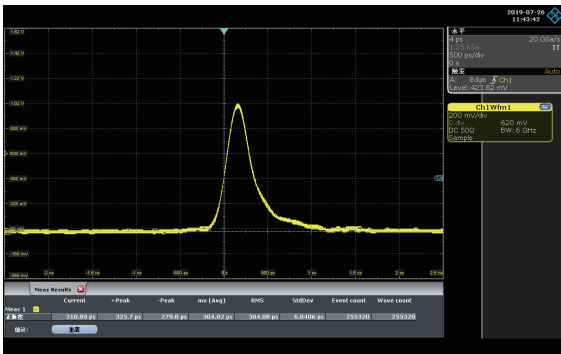
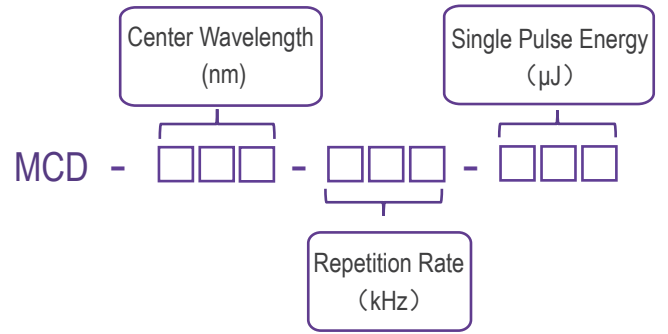

Typical Pulse

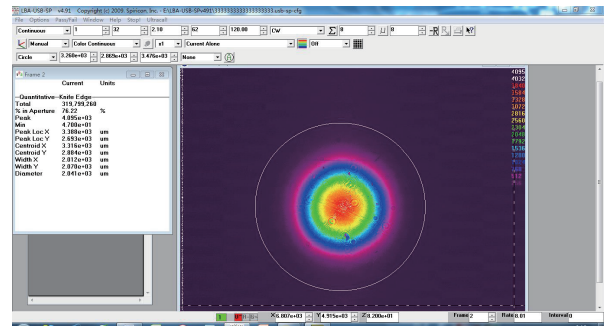

Beam Profile

Mechanical Drawings (in mm)

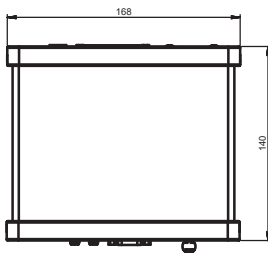
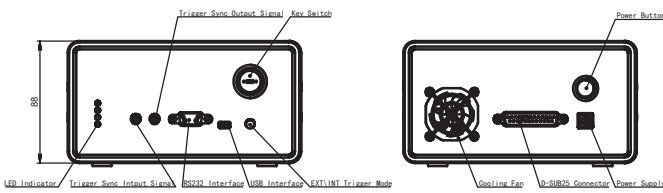

Power Supply

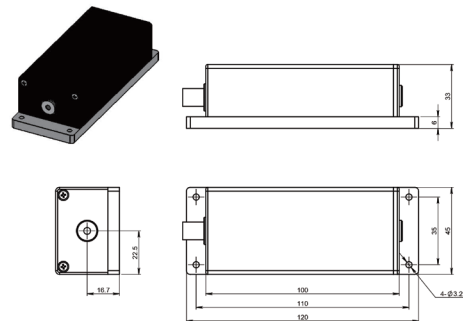

Laser Head (middle laser outlet)

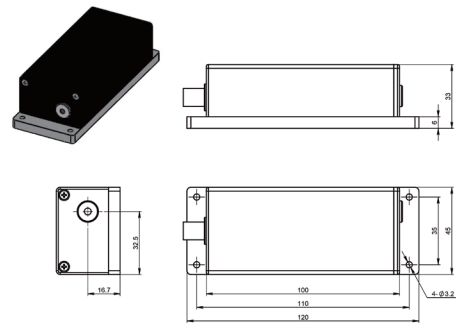

Laser Head (side laser outlet)

