

PA-1 Series Conduction Cooled Polygonal Diode Laser Array

The PA-1 series of conductive cooled polygonal diode laser array is a high peak power product developed by RealLight for use at high temperatures of 60°C. The PA-1 series is composed of six hexagonally arranged stacks, with 1 ~ 4 bars in each stack, and each bar has a power of 100W/200W. Other wavelengths and packaging forms can be customized.

Key Features

- ◆ AuSn solder for packaging
- ◆ High temperature application
- ◆ High peak power
- ◆ High reliability

Applications

- Pumping source
- Illumination
- Laser processing
- Scientific research

Technical Specifications

Optical Parameters		
Center Wavelength λ_c (nm)	790-812	
Wavelength Tolerance $\delta\lambda_c$ (nm)	±3	
Output Power per Bar (W)	100	200
Number of Bars per Stack	1-4	1-3
Bar-to-Bar Pitch (mm)	0.43	0.55
Spectral Width (FWHM) (nm)	<6	
Fast Axis Divergence Angle (FWHM) (°)	≤40	
Slow Axis Divergence Angle (FWHM) (°)	≤10	
Wavelength Temperature Coefficient (nm/°C)	~0.3	
Electrical Parameters		
EO Conversion Efficiency (%)	≥50	
Threshold Current I_{th} (A)	≤20	≤30
Operating Current I_{op} (A)	100	220
Operating Voltage V_{op} of each Bar (V)	≤2.1	
Duty Cycle (%)	≤0.8%@2400W	≤0.6%@3600W
Pulse Width (μs)	≤300	
Repetition Rate (Hz)	≤25	≤20
Environment Parameters		
Operating Temperature (°C)	-40~65	
Storage Temperature (°C)	-45~85	

1. Wavelengths from 940nm to 960nm available upon request.
2. Custom number of bars and bar-to-bar pitch are available upon request.
3. The installation and wiring can be customized to meet the customer's requirements.

Part Numbering Schema

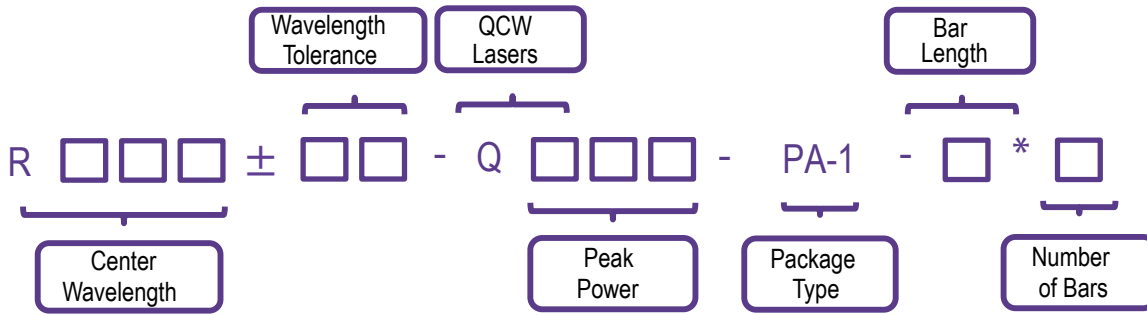

Mechanical Drawings (in mm)

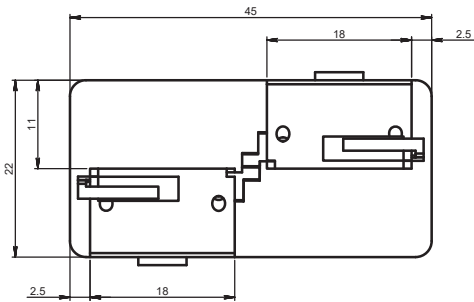
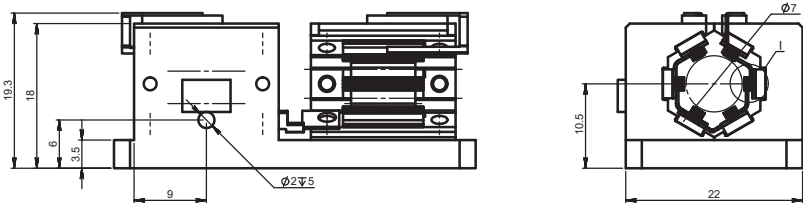

PA-1_0.43_100W

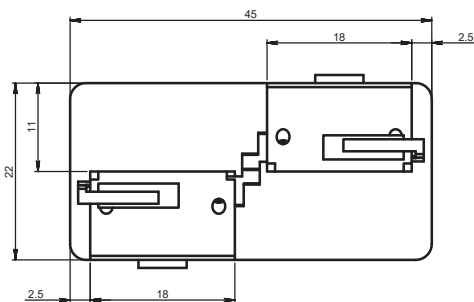
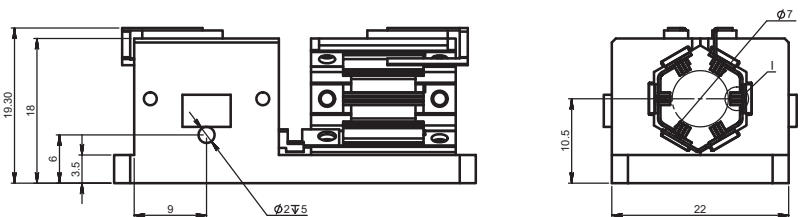

PA-1_0.55_200W

