

# NLM Series Dual-wavelength Narrow Linewidth Laser



## Key Features

- ◆ Linewidth < 0.1nm for each wavelength
- ◆ Excellent wavelength stability  $\pm 7\text{pm}@4\text{h}$
- ◆ Constant frequency interval, support difference algorithm
- ◆ Built-in TEC, power stability  $\pm 2\%$
- ◆ Contains PC control, emergency stop button, short circuit protection functions

## Applications

Raman spectroscopy Bio-instrumentation

## Technical Specifications

Optical Parameters		
Center Wavelength (nm)	784/785	785/1064
Output Power (mW)	500/500	500/800
Wavelength Tolerance (nm)	$\pm 0.5$ (each wavelength)	
Linewidth, each wavelength (nm)	<0.1	
Wavelength Stability	$\pm 7\text{ pm}@4\text{h Typ.}$	
Power Stability	$\pm 2\% @4\text{h Typ.}$	
SMSR	40dB	
System Parameters		
Adjustability % Full Power	0~100%	
Warm up Time (min)	15	
Modulation Input	Analog signal 0~5V	
Control Interface	USB, BNC	
Connector	SMA905, FC/PC	
Output Fiber	105 $\mu\text{m}$ , 0.22 NA	
Supply Voltage	+5VDC	
Power Consumption	<20W Typ.	
Storage Humidity	0~70% RH	
Storage Temperature ( $^{\circ}\text{C}$ )	-10~60	
Operating Temperature ( $^{\circ}\text{C}$ )	10~35	
Weight (kg)	1.2	
Dimensions (mm)	168x88x140	

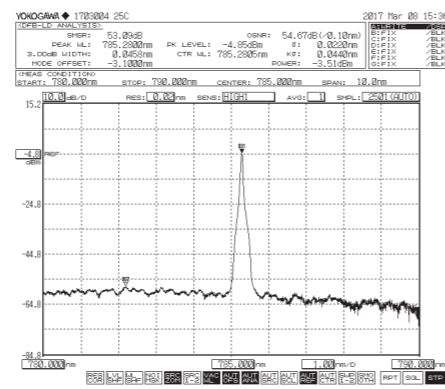

785nm laser spectrum (SMSR > 40dB)

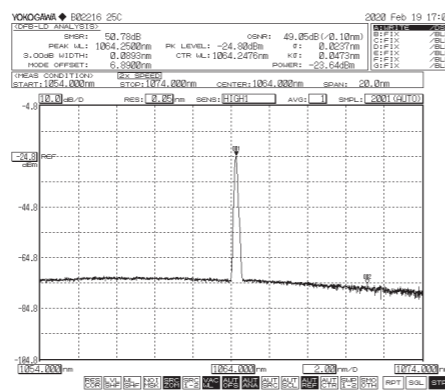

1064nm laser spectrum (SMSR > 40dB)

## Ordering Information

Wavelength (nm)	Output Power (mW)	Part Number	Connector
784/785	500/500	NLM-784/785-IF(S)-500/500	SMA905
	500/500	NLM-784/785-IF(F)-500/500	FC/PC
785/1064	500/800	NLM-785/1064-IF(S)-500/800	SMA905
	500/800	NLM-785/1064-IF(F)-500/800	FC/PC

## Part Numbering Schema

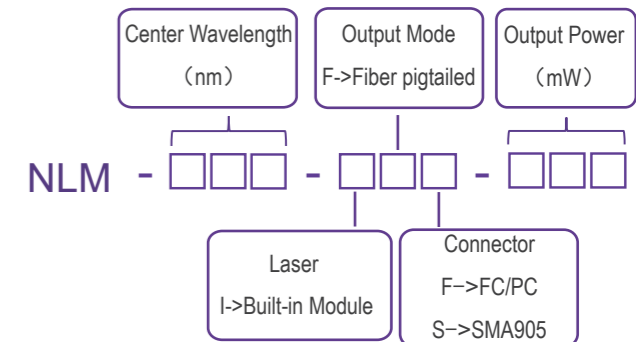

## Mechanical Drawings (mm)

