

# 09HHL Diode Laser Components

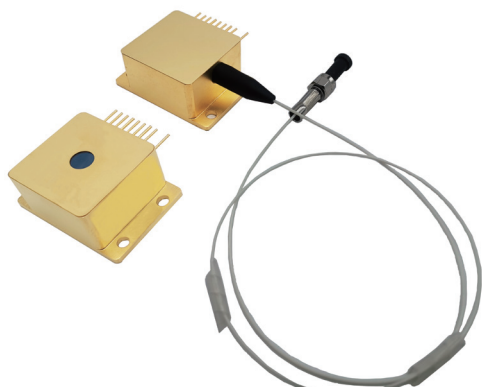

09HHL diode laser components are Reallight's AW series single emitter laser modules, available in fiber coupled or free space configurations. The free space output lasers feature excellent beam pointing stability, while the fiber-coupled output lasers deliver high coupling efficiency, good beam quality, efficient heat dissipation, compact size, high power stability and more. All 9-pin HHL packaged lasers are equipped with TE cooler, thermistor and photodiode.

## Key Features

- ◆ Efficient heat dissipation
- ◆ High reliability
- ◆ Superior power stability
- ◆ Excellent beam quality
- ◆ Various wavelengths

## Applications

- Medical application
- Laser processing
- Pumping source

## Technical Specifications (25°C)

Package Type		09HHL-T (Free Space)		09HHL-T (Fiber Pigtailed)				09HHL-TG (Narrow Linewidth)			
Center Wavelength (nm)		808		450	638	808	9XX	1064	808	976	
Optical	CW Output Power / Pop (W)	3	10	4	1	8.5	15	10	6	9	
	Wavelength Tolerance (nm)	±3,±10								±0.5	
	Spectral Width / Δλ (nm)	<4								<0.3	
	Temperature Drift of Wavelength / Δλ/ΔT (nm/°C)	0.3								0.01	
Electrical	Threshold Current / Ith (A)	0.37	1.39	0.4	0.4	1.4	0.7	0.7	1.5	0.6	
	Operating Current / Iop (A)	3.1	11	3.5	1.5	11	18	13.5	11.5	12	
	Operating Voltage / Vop (V)	2.3	1.9	4.4	2	2	1.9	1.8	2	1.9	
	PD Parameter / Ipd (μA)	<2000									
	Thermistor / Rt (kΩ/β (25°C))	10±5%/3450									
	TEC Max Current Imax (A)	6									
	TEC Max Voltage Vmax (V)	9.8									
Slope Efficiency / ηes (W/A)	1.0	1.0	0.9	1.0	0.9	0.9	0.8	0.8	0.8		
Fiber	Fiber Core/Cladding Diameter Dcore (μm)	—		105/125, 200/220							
	Fiber Length / L (cm)	—		100±10 (customizable)							
	Numerical Aperture / NA	—		0.22							
	Connector	—		FC/PC, SMA905, bare ferrule							

## Other Parameters

Parameter	Operating Temperature /°C	Operating Relative Humidity /%	Storage Temperature /°C	Storage Relative Humidity /%	Lead Soldering Temperature (max/°C)
Min	10	-	-20	-	-
Max	30	75	70	90	250(10Sec.)

## Order Information

Package	Wavelength (nm)	Output Power (W)	Part Number
09HHL-T (Free Space)	808	3	R808±10-3WW-09HHL-T
	808	10	R808±10-10WW-09HHL-T
09HHL-T (Fiber Pigtailed)	450	4	R450±10-4WF-09HHL-T
	638	1	R638±10-1WF-09HHL-T
	808	8.5	R808±10-8.5WF-09HHL-T
	9xx	15	R9xx±10-15WF-09HHL-T
09HHL-TG (Narrow Linewidth)	1064	10	R1064±10-10WF-09HHL-T
	808	6	R808±0.5-6WF-09HHL-TG
	976	9	R976±0.5-9WF-09HHL-TG

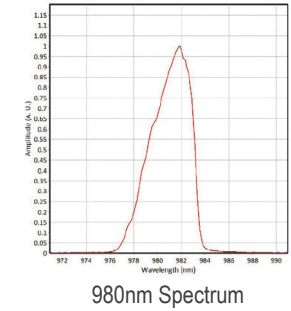
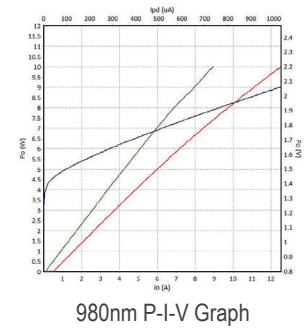
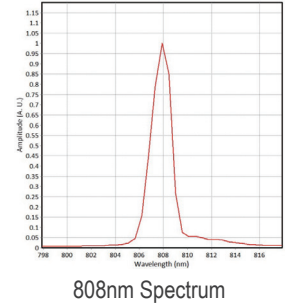
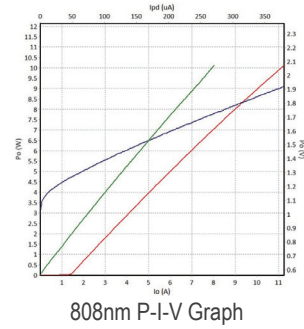

## Part Numbering Schema

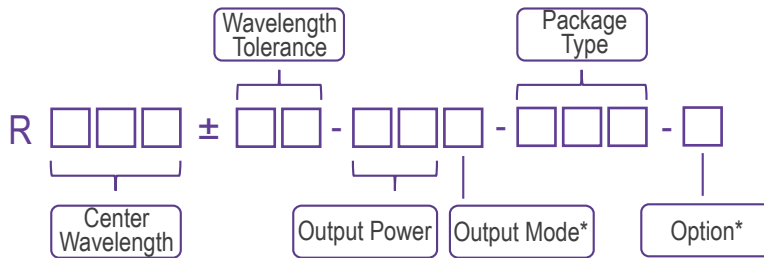

\*Output Mode: F - Fiber Pigtailed    W - Free Space

\*Option: T - TEC    G - Narrow Linewidth

## Mechanical Drawings (in mm)

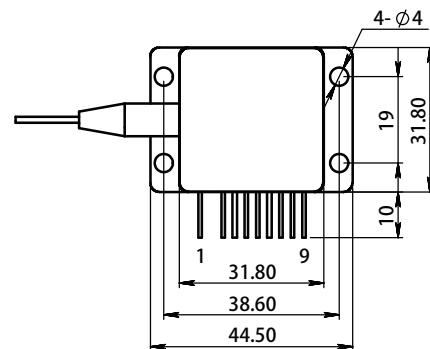
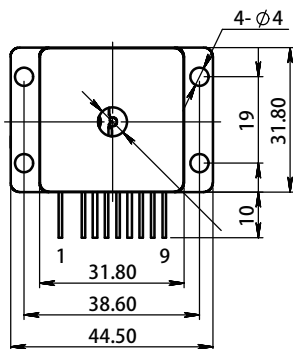
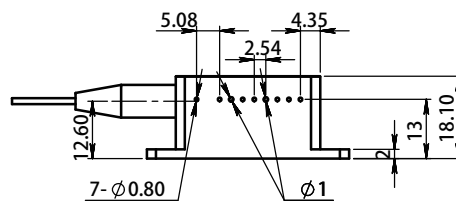
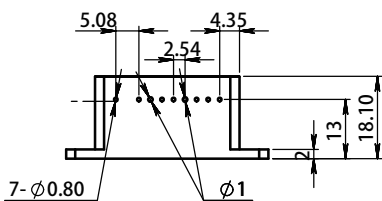

Pin	Function	Pin	Function
1	TEC(-)	6	Laser (-)
2	Case	7	PD(P)
3	Laser (+)	8	PD(N)
4	Thermistor	9	TEC (+)
5	Thermistor		

