



06LB Diode Laser Components

06LB diode laser components are RealLight's AW series laser modules, available in fiber-coupled configuration with single emitter. Equipped with photodiode and thermistor, these lasers feature compact size, superior power stability, high reliability and more.

Key Features

- ◆ Compact size
- ◆ High reliability
- ◆ Superior power stability
- ◆ Excellent beam quality
- ◆ Various wavelengths

Applications

- Pumping source
- Laser processing
- Scientific research

Technical Specifications (25°C)

Package Type		06LB			06LB-G		06LB-P	
Center Wavelength (nm)		808	9XX	1064	808	976	808	980
Optical	CW Output Power / P _{op} (W)	8.5	15	10	6	9	2	5
	Wavelength Tolerance (nm)	±3, ±10			±0.5		±10	
	Spectral Width / Δλ (nm)	<4			<0.5		<6	
	Temperature Drift of Wavelength / Δλ/ΔT (nm/°C)	0.3			0.01		0.3	
	Feedback Protection (dB) (1030-1100nm)	>40(Optional)			-		-	
Electrical	Threshold Current / I _{th} (A)	1.4	0.7	0.7	1.5	0.6	0.5	0.6
	Operating Current / I _{op} (A)	11	18	13.5	11.5	12	2.3	6
	Operating Voltage / V _{op} (V)	2	1.9	1.8	2	2	2	2
	Slope Efficiency / η _{es} (W/A)	0.9	0.9	0.8	0.8	0.8	0.9	0.9
	PD Parameter / I _{pd} (μA)	-			<2000		-	
	Aiming Beam - Output power P _a (mW)	-			-		2	
	Aiming Beam - Wavelength λ _a (nm)	-			-		650±10	
	Aiming Beam - Voltage V _a (V)	-			-		2.2	
Thermistor / Rt (kΩ/β (25°C))	-			10±1%/3450				
Fiber	Fiber Core/Cladding Diameter D _{core} (μm)	105/125, 200/220						
	Fiber Length / L (cm)	100±10 (Customizable)						
	Numerical Aperture / NA	0.22						
	Connector	FC/PC, SMA905, bare ferrule						

Other Parameters

Parameter	Operating Temperature /°C	Operating Relative Humidity /%	Storage Temperature /°C	Storage Relative Humidity /%	Lead Soldering Temperature (max/°C)
Min	10	-	-20	-	-
Max	30	75	70	90	250(10Sec.)

Order Information

Package	Wavelength (nm)	Output Power (W)	Part Number
06LB	808	8.5	R808±10-8.5WF-06LB
	9XX	15	R915±10-15WF-06LB
	1064	10	R1064±10-10WF-06LB
06LB-G	808	6	R808±0.5-6WF-06LB-G
	976	9	R976±0.5-9WF-06LB-G
06LB-P	808	2	R808±10-2WF-06LB-P
	980	5	R980±10-5WF-06LB-P

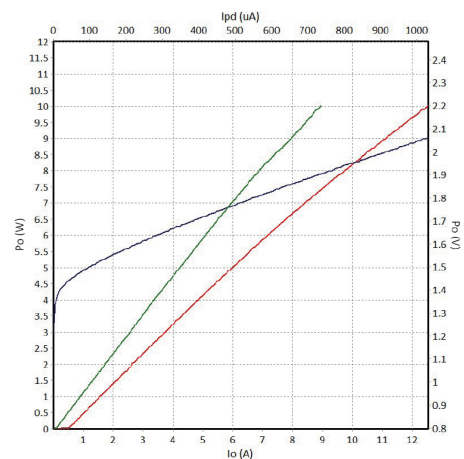

980nm P-I-V Graph

Part Numbering Schema

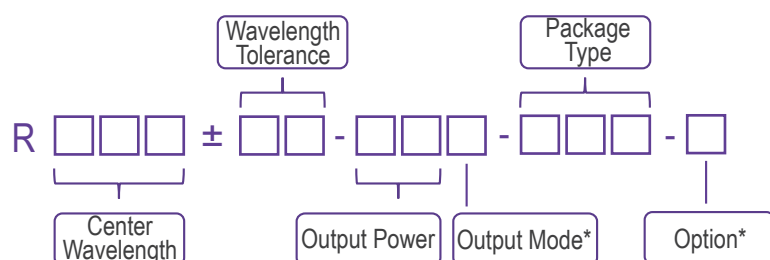

*Output Mode: F - Fiber Pigtailed

*Option: G - Narrow Linewidth

P - Aiming Beam

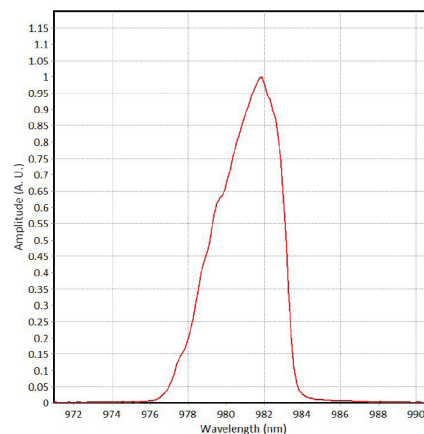

980nm Spectrum

Mechanical Drawings (in mm)

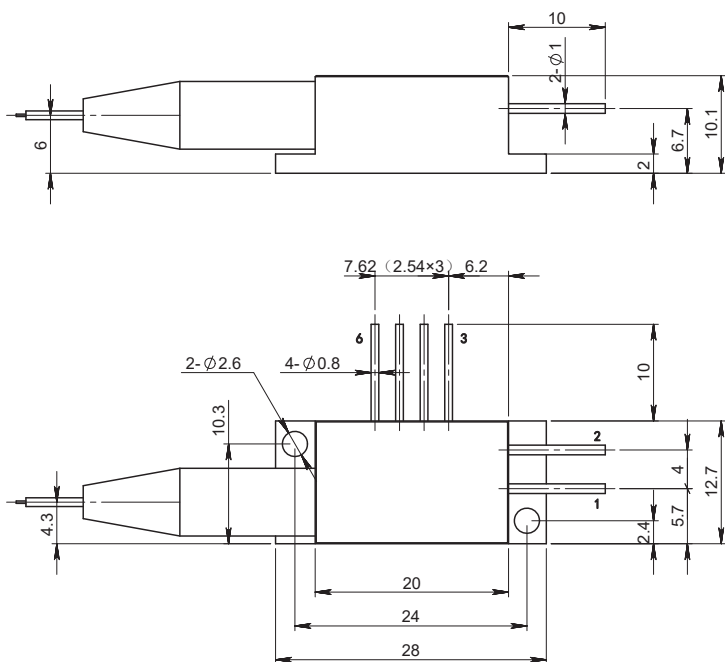

Pin	Function
1	Laser (+)
2	Laser (-)
3	Thermistor
4	Thermistor
5	PD(N)
6	PD(P)

